

# An Efficient Western Energy Imbalance Market with Conflicting Carbon Policies

William W. Hogan<sup>1</sup>

A reform of the Western Energy Imbalance Market should target the right problem. Import leakage is a problem; resource shuffling is a solution. Proposed modifications for the existing EIM design target the wrong problem and would work at cross purposes to the very reasons for the EIM's existence. There is a better approach that would address the right problem and preserve the critical elements of the existing EIM design.

September 28, 2017

## Introduction

The launch of the new web site for the Western Energy Imbalance Market (EIM) serves as a milestone for a critical element of an open and non-discriminatory electricity market.<sup>1</sup> Operated by the California Independent System Operator (CAISO), the EIM is a response to the growing challenges of changing electricity markets, especially in managing the short-term dynamics of efficient operation of the grid in the presence of increasing penetration of intermittent renewable energy generation.

The small volumes in the EIM do not imply that it is unimportant. Rather, the real-time imbalance market sets prices and expectations for all other transactions. The design of the imbalance market is the most important element in an open access and non-discriminatory system for an electricity market. The EIM operates on an integrated grid where different regions have different carbon policies. In particular, the California cap-and-trade system encompasses electricity trade with regions that are otherwise not covered by the same carbon policies.

This essential market has been criticized for allowing “resource shuffling” and unwanted effects on carbon emissions. The CAISO has been working on a series of possible modifications of the EIM to mitigate the impacts of resource shuffling. The EIM's own importance warrants close attention to developments in the market design. In addition, other organized markets have suggested adopting the proposed modifications for the EIM (PJM, 2017).

The latest proposals for revising the EIM are problematic. The proposed modifications would reintroduce errors of the past that fundamentally undermine an open and non-discriminatory market in electricity. Arguments that dismiss these problems as too small to be important should, at a minimum, bear a burden of proof for ignoring the unhappy prior experience. A better approach

---

<sup>1</sup> See July 11, 2017 CAISO press release for [www.westerneim.com](http://www.westerneim.com).

would be to revisit the concern with resource shuffling and recognize that the main elements of the existing EIM dispatch should be preserved.

## **Coordination for Competition**

Although it is not easy, the CAISO is able to manage the interacting requirements of balancing supply and demand, while dispatching within the static and dynamic limits of transmission grid power flows, to minimize costs and maintain secure operations. The existing EIM applies the basic framework by following the general principles of bid-based, security-constrained, economic dispatch with locational prices (LMPs) to organize the sometimes rapidly changing output of generation sources while producing the associated locational prices to support that solution (California Independent System Operator, 2017a, sec. 1.2.26.2). This basic economic dispatch is the only approach that implements open access and non-discrimination in electricity markets (Hogan & Pope, 2017, pp. 6–12).

The new EIM web site describes the process of efficient operation and reports on the substantial benefits that have been achieved through the existing market design. Part of the reason for the success of the EIM is the application of an efficient pricing mechanism that supports the dispatch. Under the simple economic dispatch framework, the prices are consistent with the dispatch, and a price-taking competitive market participant has no incentive to change its offers or to deviate from the efficient dispatch (Gribik, Hogan, & Pope, 2007).

As everyone should remember, especially those in California, this efficient market design and the associated supporting prices have not always been embraced in the electricity market. As a prominent example from 1998, the California market launched under a design rubric of a restricted ISO and a separate Power Exchange (PX). This design was built on the fallacy that it is possible to separate market transactions from transmission operations. The flawed approach had strong backing among the market participants, who dismissed analyses at the time showing that the market could not work in theory, and probably would not work in practice.

The Federal Energy Regulatory Commission (FERC) recognized the flaws in the market design, but reluctantly deferred to the consensus view of the California parties. This would turn out to be perhaps its worst decision as FERC managed the development of open electricity markets.

Amongst other features, this flawed ISO/PX design explicitly precluded economic dispatch, and required imbalance market pricing rules that could not support the associated ISO dispatch for congestion management. This created perverse incentives for market participants to manipulate offers and schedules to take advantage of the inefficient dispatch and pricing rules under the separation fallacy. By the end of 1999, the FERC found that the design was “fundamentally flawed” (Hogan, 2002), and directed the CAISO to fix the market in a process that came to be called Comprehensive Market Redesign.

In 2000 this flawed market was hit with the California electricity crisis where fundamental market conditions interacted with the broken market design to overwhelm most market participants and the regulators. After the crisis, the CAISO organized a long-term effort to arrive at a much-improved electricity market design based on the principles of bid-based, security-constrained, economic dispatch with locational prices and financial transmission rights. In essence, CAISO eventually adopted the workable design that had been explicitly rejected in the process that led to the formation of the initial California market.

The core elements of this fundamental reform were transferred to the EIM. A complication for the EIM arises from the interaction with the carbon regulations in California as administered by the California Air Resources Board (CARB). In essence, the EIM needed to straddle both market regions that are subject to carbon constraints and those regions with different approaches to treating carbon emissions. The regulations under the California cap-and-trade system require carbon emission permits for electricity generation in California, which is relatively straightforward, and for electricity imports, which is not straightforward. For both legal and practical reasons, the solution adopted for the EIM was to identify generation outside California that was deemed to provide exports to California with an accompanying settlement system that is consistent with the treatment of California resources. The basic EIM model produces a variant of an economic dispatch and efficient prices that support the economic dispatch. Market participants have no incentive to deviate from the dispatch and associated export schedules (Hogan, 2013).

## **Resource Shuffling**

This basic EIM design works. But it has been criticized because of concerns that it produces dispatch results that embody “resource shuffling” that assigns low carbon generation to California when the actual marginal source of generation might be a higher carbon emitter. The actual CARB definition of resource shuffling is somewhat vague.

“Resource Shuffling” means any plan, scheme, or artifice undertaken by a First Deliverer of Electricity to substitute electricity deliveries from sources with relatively lower emissions for electricity deliveries from sources with relatively higher emissions to reduce its emissions compliance obligation.” (California Air Resources Board, 2017)

An underling difficulty is the implicit assumption that the concept of “deliveries [to load] from sources” is a well-defined concept. In fact, power flows intermingle from all sources and the “deliveries from sources” are just after-the-fact accounting conventions that should be better labeled as “deemed deliveries.” The substitutions are all on paper. Discussions of CARB concerns, that the EIM description of deliveries from sources to load does not capture the “atmospheric effect of ISO load relying on resources external to the ISO balancing authority,” reveal how the accounting fiction is confused with the physical reality (California Independent System Operator, 2017b, p. 9).

In addition, the ambiguity stems from the inherent characteristics of different carbon policies operating under a single electricity market. The EIM must accommodate a market where the effective costs and prices for the same electricity have a different meaning and interpretation for different participants. There appears to be no perfect solution to this problem other than to extend the same carbon policy across the entire electricity grid. However, adopting a common carbon policy is not likely to happen soon.

Absent an operational definition of resource shuffling, the practice has been to identify transactions that are protected by a “safe harbor” as being deemed not to be resource shuffling. The EIM transactions have had this safe harbor protection (California Air Resources Board, 2017). However, the EIM rules have been a subject of continuing debate about the impact of resource shuffling and the CAISO has been discussing a series of modifications of the market design to address the issue of what can be deemed by CARB to be an acceptable import into California.

The problem is fundamental, and the CAISO recognizes this is a challenge. “[T]he solution must balance the objective of minimizing secondary dispatch with optimization solution performance and price/dispatch consistency.” (California Independent System Operator, 2017b, p. 5) But the CAISO and other market participants have not defined the basic principles and shown that there is a consistent market design that is also consistent with these principles. In part, the nature of the problem involves defining a counterfactual that would serve as the guide for approximating the effect of the carbon regulations, while respecting the differences across the region.

The approach in the CAISO proposed revision of the EIM stage model is to start with a counterfactual that is a dispatch with different carbon policies but without imports. And the rules try to limit the deemed sources of imports that are allowed.

From California’s perspective, an alternative counterfactual could begin with the ideal case that would be the result of a common carbon regime across the grid. The simplest case would be a common price on carbon emissions. This cost would be incorporated in all generation offers, just as it is already in California. Then the EIM would apply the standard principles of economic dispatch. The power prices would differ across locations because of losses and transmission congestion. But at each location the price of power would be the marginal cost of energy (including a capacity scarcity component) at that location plus the marginal emissions cost at that location. The dispatch would not specify the sources of individual deliveries to loads. The benefits captured by generators would reflect the difference between their individual emission costs and the marginal costs implied at their location. Hence, renewable generators, with essentially zero variable energy costs and no emission charges, would capture the greatest benefit. Marginal fossil units would just break even on their emissions and marginal costs of energy. The basic principles of economic dispatch would be preserved, and the prices would support the solution.

## **Two-Stage EIM Design**

What is happening, by contrast, is that the CAISO and market participants have been proposing rules that seem in the spirit of reducing or preventing resource shuffling, by separating markets and discriminating across participants, but without any analysis of the implications for the operation of the EIM or the larger electricity market.

In effect, the concerns with resource shuffling have given rise to efforts to discriminate in the operation of the market dispatch outside California, and this discrimination is at odds with the very principles of non-discrimination. Furthermore, the results diverge from the principles of economic dispatch and the prices do not support the solution.

The latest example is the “EIM Greenhouse Gas Enhancement, Revised Draft Final Proposal,” for the future operation of the EIM (California Independent System Operator, 2017b). The title for the June 23, 2017, document reveals the essence of the iterative struggle. What is described therein is a two-stage system for separating markets: first employing a counterfactual to determine which generation will in fact be allowed to sell into California, and then to perform a bid-based economic dispatch following rules like the existing EIM, but with the added constraints from the first-stage results. In effect, the first stage seeks to set up the rules for discriminating, and the second stage would implement the discriminatory dispatch.

There is no analysis of why this two-stage approach provides proper incentives or how it relates to the fundamentals of market design. The proposed EIM design appears to be a compromise among the stakeholders. Although sometimes compromise is appropriate, there are other situations where compromise to accommodate different interests undermines the entire effort, as with the ISO/PX failure.<sup>2</sup>

Unfortunately, the proposed two-stage EIM model does not work in theory. The proposed two-stage design introduces its own separation fallacy. Because of the interactions with transmission and ramping constraints, it is possible to construct hypothetical cases where what has been described as resource shuffling still occurs. Hence, on its face the revised proposal does not meet the objective. Furthermore, and more fundamentally, the revised proposal would undo the underlying principles of the basic market design. In short, like with the original ISO/PX contortions, market participants would have the incentive and the opportunity to distort their offers and deviate from the intended dispatch.

### ***Two-Stage EIM Model Incentives<sup>3</sup>***

The CAISO proposal outlines a two-stage determination of a reformulated EIM solution for real-time dispatch and pricing. The first stage allows no CA imports, but solves for a counterfactual

---

<sup>2</sup> Similar problems appeared in PJM, New England, and ERCOT with early markets designs that did not follow the principles of bid-based, security-constrained, economic dispatch with locational prices (Hogan, 2002).

<sup>3</sup> This section stands its own. However, it incorporates various off-the-record discussions. As with Chatham House rules, the discussions were not for attribution: “When a meeting, or part thereof, is held under the Chatham

base level of dispatch that ignores carbon costs outside CA. The second stage determines CAISO imports subject to the constraint that only supplies outside CA that have capacity above the base level from the first stage can be deemed to provide imports. Dispatch may be below the base level for generators, but dispatch down does not create any headroom on the capacity constraints to allow reconfiguration to produce more imports in the second stage.

Hypothetical examples can show that the CAISO solution does not preclude what CARB would probably define as resource shuffling. The illustration in Appendix I provides one such example. It includes an interaction with transmission constraints, and produces a redispatch relative to the first-stage base levels that utilizes higher carbon producing generators but attributes CA imports to lower carbon producing generators whose dispatch does not change from the base schedule.

In addition, the proposed CAISO method faces a potentially significant problem in that the resulting prices do not support the solution. The example in the appendix illustrates this problem, but the difficulty is present even without the effect of transmission constraints.

To take a simpler illustration, assume there are no transmission constraints other than an aggregate import limit. Suppose we have two types of resources outside CA: zero emitting renewables with zero variable cost, and constant high-cost and carbon-emitting fossil plants. Thus, there is a two-step energy supply curve. Suppose the outside-CA load is greater than the outside-CA capacity of renewables. Then all the renewables would be dispatched in the first stage, to support the outside CA load, and the price would be the variable cost of the fossil fuels, say  $P^{(1)}$ . In the second stage, the same type of dispatch would be found with the energy price net of the cost of carbon still at  $P^{(1)}$ . The price as seen for CA is the energy price plus the cost of carbon  $P^{(2)} = P^{(1)} + \tau$ . All the CA imports would be deemed to be from fossil fuels, requiring permits equal to the volume of imports.

In effect, this revised two-stage EIM model would impose reverse shuffling, excluding the outside-CA renewables from the CA market. However, the prices do not support the solution. If one renewable owner submits an offer different than its variable cost, say  $P^{(r)}$ , and we have  $P^{(1)} < P^{(r)} < P^{(1)} + \tau$ , then this renewable would not be included in the first-stage dispatch, the renewable base level would be zero, and the renewable would then be dispatched in the second stage and be deemed to provide imports for CA. In this case, the demand for carbon permits would be reduced by the amount of the renewable dispatch, and renewables would be more profitable in capturing the value of an equal number of permits. In this simple case, all the prices and physical dispatch quantities would be the same, only payments for carbon permits differ. However, once there is an incentive to change the offers from the true costs, imperfect information can cause changes in the energy dispatch and prices as well. The market participants would see the revised EIM as more like a pay-as-bid market, rather than based on a market-clearing price. This would

---

House Rule, participants are free to use the information received, but neither the identity nor the affiliation of the speaker(s), nor that of any other participant, may be revealed.”

be especially problematic in the presence of transmission constraints, which are a central feature of the EIM.

A similar problem appears in the example in Appendix I. This disconnect of not supporting the dispatch is not the result of market power. The disconnect arises because of the structure of the proposed EIM two-stage design when the generation offers affect what happens in each stage. The existing EIM dispatch, with prices based on the respective LMPs, with no first stage and the base-levels all set to zero, would produce an equilibrium solution without these arbitrage opportunities. The price from the basic model would support the solution, and there would be no incentive for a price-taker to change bids.<sup>4</sup>

### ***Two-Stage Discrimination Problem***

The problem is inherent in the two-stage approach, and the solution is not in perfecting the first stage to find a better method for separating the markets and discriminating among potential imports. Any non-trivial two-stage approach would, as intended, produce discriminatory administrative constraints that apply in the second-stage. These would limit choices in the second stage and inherently produce prices as calculated by the CAISO that would have incentives for the constrained generator to get around the first-stage constraint and create head room for exports to California. This could be done, as in the examples, by manipulating the offers to avoid being selected in the first stage while remaining eligible to provide export to California in the second stage. The basic single-stage EIM avoids this problem by not having a first stage to define discriminatory rules.

The fundamental purpose of the EIM was to facilitate a solution to the difficult problem of coordinating market imbalances under the increasingly difficult conditions created by the expansion of reliance on intermittent renewables. The existing EIM design addresses this problem in a manner that supports efficient operations, open access and non-discrimination. The proposed EIM modifications work in the opposite direction. A two-stage approach would be harder to implement in the brief period available for imbalance adjustments. With its expanded computational difficulty, inefficient dispatch, and inconsistent prices, the proposed EIM revisions could easily make it harder, not easier, to coordinate wider market operations. Hence, the proposed resource-shuffling cure could be worse than the disease.

### **Unpacking the Design Challenge**

The design challenge confronts two related but distinct problems. One addresses the change in the volume of imports and the other concerns the composition of imports. The change in the physical dispatch, and the interaction with imports, often goes under the terminology of “leakage,” where high carbon imports are used to replace lower carbon local resources (Newell et al., 2017). By

---

<sup>4</sup> Here assuming known or auditable emission factors where the CAISO computes the emission charges. This assumes no manipulation of the carbon offers (Hogan, 2014). The manipulation uses energy offers that are harder to verify.

contrast the arguments about the alleged problems with resource shuffling focus on the composition of imports. When the principal substitution is through a changed volume of imports, the meaning of leakage is clearer. However, the CARB rules include treatment of external generators deemed to provide imports, which is a different situation. The discussion surrounding the EIM has used the general term leakage to at times refer to both import leakage and the deemed composition of imports, which complicates the discussion. To unpack the design challenge, consider separately the effects of changing the volume of imports (import leakage), and the effects of changing the composition of imports while holding the level of imports constant (resource shuffling).

Although import leakage and resource shuffling interact, they are not the same thing. For example, if the external region had a high but common emission rate across all generation sources, there could be import leakage without any resource shuffling. High emission imports could substitute for lower emission local resources, but the deemed composition of those external resources could be shuffled with no consequential effect. Import leakage would be a problem, not resource shuffling.

Returning to the counterfactual based on a common carbon policy, this reconsideration of resource shuffling highlights the benefits under the current EIM compensation scheme. The description of the benefits also highlights the import leakage problem that is conflated with imports, but can be addressed with a separate policy instrument.

### ***Benefits of Resource Shuffling***

Under the one-stage EIM, payments for imports include the implied marginal cost for carbon emissions from imports, and these payments flow to the generators deemed as supplying CA imports. These generators then take on an obligation to purchase carbon emission permits from CA. The net effect for these generators is that they capture the cost difference between their individual emissions and the marginal system cost of emissions. This is like the outcome under a common carbon price across the EIM. If the total dispatch were to be the same as with a common carbon policy, then the payment outcome would be the same for the exporting generators, unlike the result of the two-stage EIM proposal.

This focus on the incentive effects of payments within the hybrid cap-and-trade system assumes that the purpose is to approximate the effect of a common carbon policy and not to manipulate the demand for carbon permits. In the short-term, the two-stage EIM proposal would have the effect of discriminating to increase the total demand for carbon permits. This creates perverse incentives for operations, and the short-term operating incentives of the two-stage EIM would translate into long-term investment incentives that would compound the problems. In effect, the revised two-stage proposal would discriminate against low carbon-emitting resources, exactly the opposite of the long-term goal of providing incentives through the market for cleaner energy generation. Fixing this incentive problem would produce a deemed dispatch with a different, and probably



lower demand for permits, or a lower permit price. This would be a good outcome by eliminating the problematic elements of the proposed two-stage design.

In the current one-stage EIM, if the only effect of resource shuffling were to rearrange the designation of deemed imports, then resource shuffling would not affect short-run emissions and would conform better to the long-run goal of providing better incentives for investment.

### ***Costs of Import Leakage***

The material benefit in providing payments closer to the outcome of a common carbon policy is clouded by the problem of changing the dispatch. The concern is that the single-stage EIM with resource shuffling does not achieve the same dispatch as would appear under a common carbon policy.

This distinction between import leakage and resource shuffling is important. Import leakage is a problem in affecting aggregate emissions, and resource shuffling is a solution in allocating the payments among the deemed imports. Conflating the two issues leads to the two-stage proposals that cause other serious harms and could unravel the so-far successful EIM operations.

### ***Single Stage EIM Extension***

If resource shuffling is a solution and import leakage is a problem, it would be better to focus on the problem in considering reform of the single-stage EIM.

Since any non-trivial two-stage approach that would create perverse incentives, and precipitate a collapse of the good features of the EIM, the natural policy would be to preserve a single-stage model. The usual discussion of the import leakage problem focuses on a solution by imposing import charges and export payments that approximate the aggregate import impact on the local dispatch (Newell et al., 2017).

It is recognized that these charges, based on an estimate of the marginal emission costs, are only an approximation of the effects of a common carbon policy. The aggregate charges do not fully account for the possibly complicated effects of transmission flows and constraints (Rudkevich & Ruiz, 2012). But the hope is that the approximate charges can capture the major effects of import leakage.

The basic formulation of import charges set at the marginal cost of external emissions does not speak to the resource shuffling effect, and it is usually described in the context of a carbon tax where the payments issue and resource shuffling are ignored. Hence, one possible criticism of the import charging approach based on the marginal cost of emissions is that it is silent on the distribution of the money or the payments. The charging approach says nothing about the matter of resource shuffling.

An adaptation of this import charging approach to the single-stage EIM would be to impose an estimated ex ante fee on deemed imports of electricity, with the fee set equal to an estimate of the

difference between price under a hypothetical common carbon policy and the price that will emerge under the single-stage EIM implementation. The associated payments mechanism of the single-stage EIM would apply to the net value of the marginal CA imports at the price obtained from the deemed import constraint minus the import leakage fee. The added fee, to deal with import leakage, would be collected from load for all imports, but would not be paid to the deemed imports. Hence, at the margin for the imports into CA, the prices would be consistent with the dispatch and the marginal generator would be indifferent as to whether it was deemed to be part of the CA imports. See Appendix II for further details.

This approach would be vulnerable to the same criticism as any such charging regime in that it would require estimating an implicit price that is hard to obtain. The version here would be better than without the EIM construct in that the estimated number would be smaller, being not the total value of the marginal carbon imports but only the difference between the value under the counterfactual common carbon policy and the implied value that would otherwise result from import leakage. The policy instrument (the differential carbon charge) would be targeted to the principal problem (import leakage).

The result would be a single-stage EIM as now, but with the addition of an added incremental charge on deemed imports that would be scaled according to the analysis of the approximate scale of import leakage. Efficient resource shuffling under the EIM would affect the payments for deemed imports. The prices from the EIM economic dispatch would support the dispatch, and implementation of the EIM would be no more difficult than in the existing design.

The market design would not confuse real dispatch effects with deemed transactions, would be easier to explain, and would not break what isn't broken.

## **Conclusion**

As always, the real-time balancing market is the lynchpin for providing good incentives that drive day-ahead and longer-term forward electricity markets. Even though the balancing volumes may seem small, efficient pricing is critical. As with the prior experience with the ISO/PX model, and similar problems in other organized markets, compromise on this point is not a good idea. The existing EIM model is workable, and produces a dispatch and prices that are mutually consistent and support the solution. The critique of the existing EIM conflates the effects of import leakage with the effects of resource shuffling. However, they are not the same. Import leakage is a problem and resource shuffling is a solution. A targeted solution to deal with import leakage can leave core elements of the existing single-stage EIM unchanged. The alternative approach of the two-stage EIM proposal would not address the right problem but would cause unintended collateral damage. The proposed two-stage modifications would work at cross purposes to the very reasons for the existence of the EIM. There is a better approach that would address the right problem and preserve the critical elements of the existing EIM design.

## Appendix I: Example of Resource Shuffling in the CAISO Approach and Incentives to Modify Offers

The figure sets up the basic assumptions for the hypothetical two-stage dispatch. For simplicity, following the formulation in the CAISO proposal, “the example ignores day-ahead and base schedules, ancillary services, transmission losses, startup and minimum load costs, and inter-temporal constraints, focusing on a single time period.” (California Independent System Operator, 2017a)

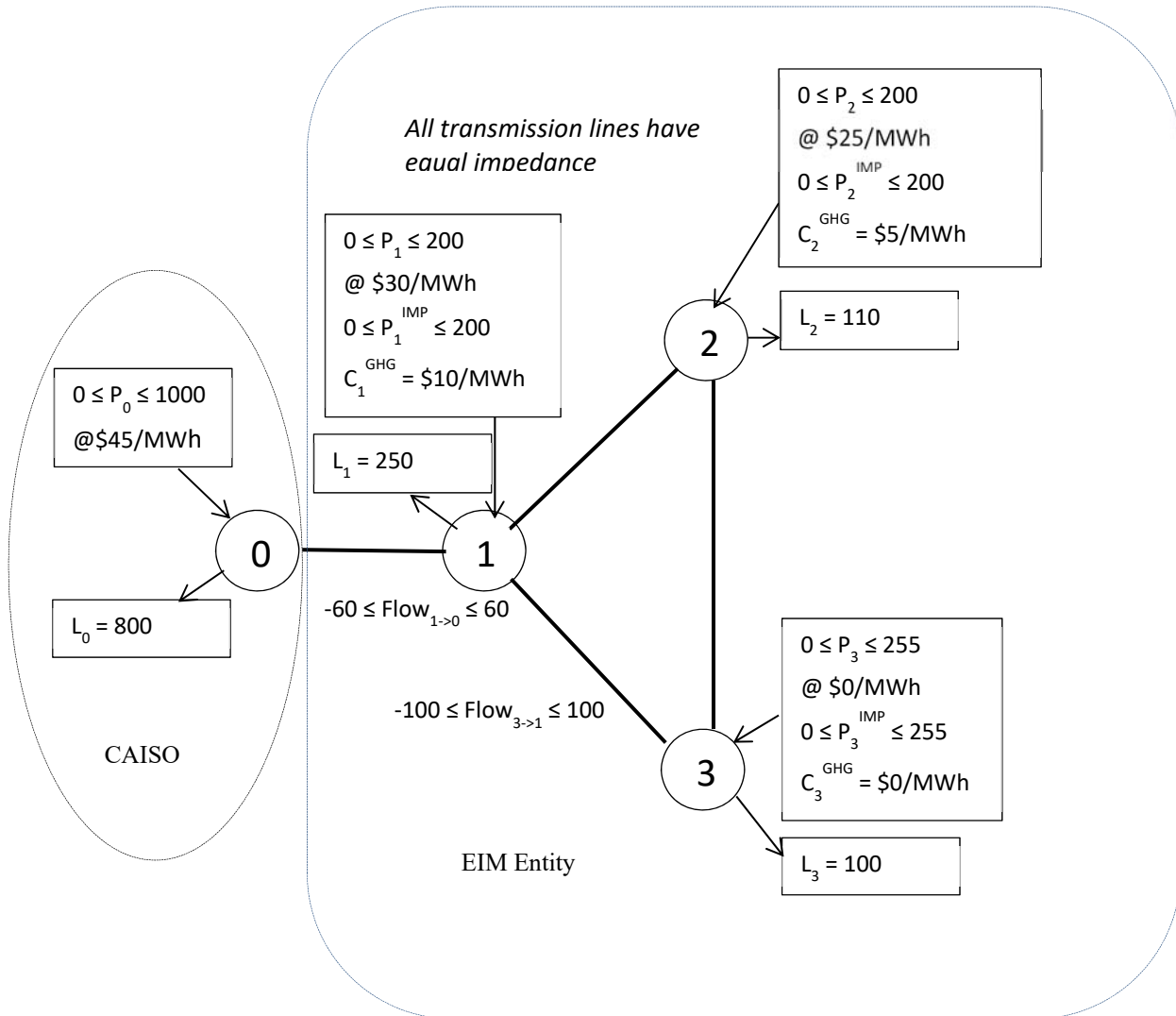

In the first stage, CAISO proposes to optimize the schedules while holding the imports into CAISO from EIM Entities to be less than or equal to zero. In this example, the first stage solution is for the above example is:

$$P_0^1 = 800 \text{ MW}, P_1^1 = 105 \text{ MW}, P_2^1 = 100 \text{ MW}, P_3^1 = 255 \text{ MW}.$$

Since  $P_1$  and  $P_2$  are not dispatched to their maximum levels in the first stage, imports into CAISO can be scheduled from these resources in the second stage. Up to 95 MW of import can be scheduled on  $P_1$  and up to 100 MW can be scheduled on  $P_2$ . No import can be scheduled on  $P_3$  since it is scheduled to its maximum capability in the first stage.

The second stage solution is:

$$P_0^2 = 740 \text{ MW}, P_1^2 = 165 \text{ MW}, P_2^2 = 100 \text{ MW}, P_3^2 = 255 \text{ MW} \text{ and } P_1^{\text{Import}} = 0 \text{ MW}, P_2^{\text{Import}} = 60 \text{ MW}, P_3^{\text{Import}} = 0 \text{ MW}.$$

Note that 60 MW of import is ascribed to  $P_2$  even though its schedule does not change from the first stage solution while 0 MW of import is ascribed to  $P_1$  even though its schedule is increased by 60 MW. Assuming that the carbon bid costs are based on expected emissions rates, CAISO will ascribe \$300 of emissions to  $P_2$  while actually causing \$600 of emissions from  $P_1$ . The approach allows what CARB seems to define as leakage.

Even if CARB decides that this “leakage” is acceptable, the approach gives an incentive to participants to modify their bids to capture carbon costs in their payments. This can occur even when the participants do not have market power.

In the above example, the shadow prices on the constraints are:

$$\text{Power Balance } \$45/\text{MWh}, \text{Flow}_{1 \rightarrow 0} \text{ } -\$10/\text{MWh}, \text{Flow}_{3 \rightarrow 1} \text{ } -\$15, \text{Carbon } -\$5/\text{MWh}.$$

The LMPs at the nodes are:

$$\text{LMP}_0 = \$45/\text{MWh}, \text{LMP}_1 = \$30/\text{MWh}, \text{LMP}_2 = \$25/\text{MWh}, \text{LMP}_3 = \$20/\text{MWh}.$$

When settling  $P_3$  it will be paid \$5100 for energy and \$0 for carbon considering that no imports are scheduled from that generator. This yields a profit of \$5100.

The market rules give  $P_3$  an incentive to modify its offer costs to try to capture some of the carbon payments. It has the incentive to increase its energy offer to a level that would reduce its schedule in the first stage while allowing it to be scheduled in the second stage with an assigned import. Suppose that  $P_3$  were to increase its energy offer to \$21/MWh. This exceeds its expected LMP but is not so great that it would not be scheduled to provide an import.

In this revised example, the first stage solution is:

$$P_0^1 = 800 \text{ MW}, P_1^1 = 55 \text{ MW}, P_2^1 = 200 \text{ MW}, P_3^1 = 205 \text{ MW}.$$

Since  $P_1$  and  $P_3$  are not dispatched to their maximum levels in the first stage, imports into CAISO can be scheduled from these resources in the second stage. Up to 145 MW of import can be scheduled on  $P_1$  and up to 50 MW can be scheduled on  $P_3$ . No import can be scheduled on  $P_2$  since it is scheduled to its maximum capability in the first stage.

The second stage solution is:

$$P_0^2 = 740 \text{ MW}, P_1^2 = 165 \text{ MW}, P_2^2 = 100 \text{ MW}, P_3^2 = 255 \text{ MW} \text{ and } P_1^{\text{Import}} = 10 \text{ MW}, P_2^{\text{Import}} = 0 \text{ MW}, P_3^{\text{Import}} = 50 \text{ MW}.$$

The shadow prices on the constraints are:

$$\text{Power Balance } \$45/\text{MWh}, \text{Flow}_{1 \rightarrow 0} \text{ } -\$5/\text{MWh}, \text{Flow}_{3 \rightarrow 1} \text{ } -\$15, \text{Carbon } -\$10/\text{MWh}.$$

The LMPs at the nodes are:

$$\text{LMP}_0 = \$45/\text{MWh}, \text{LMP}_1 = \$30/\text{MWh}, \text{LMP}_2 = \$25/\text{MWh}, \text{LMP}_3 = \$20/\text{MWh}.$$

When settling  $P_3$  it will be paid \$5100 for energy and \$500 for carbon considering that 50 MW of imports are scheduled from that generator. Considering the actual costs for this generator (not the offer costs), it earns a profit of \$5600. By modifying its bid to capture imports, it increases its profit by \$500.

## Appendix II: An Energy Imbalance Market model with Deemed Imports and Associated Border Charges

The adaptation of the EIM design to include a charge on imports would be a simple extension of the existing EIM design. The critical elements summarized here adapt from the discussion in (Hogan, 2013).

The basic model includes two zones for CARB carbon restrictions, described here as I and II. Zone I includes all the California generators covered by CARB. Zone II corresponds to those outside of CARB jurisdiction but inside the EIM operated by the CAISO.

In Zone I there is an implicit assumption that generators must obtain emission credits to match their carbon output. The generators in Zone I face a market price for these permits, and this cost of permits is assumed to be included in their energy offers. There is no explicit representation of emissions in Zone I and no assumptions regarding the location at which the power generated in Zone I is consumed.

The treatment of generators in Zone II is different. Generators participating in the EIM and located in this zone provide data on their respective emission rates to the CAISO. There is an assumed market price of permits that is used by the CAISO in its proposed EIM economic dispatch. The offers that generators make in the imbalance market do not include the emission cost as part of their energy offer. The emission cost is accounted for separately by the CAISO. In addition to the generation ( $g$ ) and load ( $d$ ) in Zone II, there is a set of variables for the deemed exports ( $E_{II}$ ) from generators in Zone II to load in Zone I (if any). The deemed exports are calculated by generator, but are not differentiated by destination within Zone I. The individual export costs are for the emission factor ( $e_{II}$ ) for each generator priced at the assumed market price of permits ( $C_E(E_{II}) = P_E e'_{II} E_{II}$ ). The individual exports must be less than the generation for the corresponding generator. The total exports from Zone II must be equal to the net transfers ( $-y_{II}$ ) from Zone II to Zone I, or zero if there are no positive transfers.

This is the basic EIM design. The extension discussed here would include an additional import fee ( $\delta$ ) applied to all the deemed imports into Zone I. Suppose the estimate of the optimal dispatch with a common carbon price is  $g_{II}^*$ , and the estimate of the corresponding EIM dispatch is  $E_{II}^*$ . With only a single marginal generator, the import fee estimate would be  $\delta = \partial C_E(g_{II}^*) - \partial C_E(E_{II}^*)$ . More generally, even with complicated locational differences, there would always be a common value for  $\delta$  that would result in the EIM CA import total limited to the imports that would occur with a common carbon policy. This would not reproduce the full result of a common carbon policy across the grid, but perfection is probably not possible without adopting a common policy.

The following slight generalization of the EIM is equivalent with transmission constraints for energy while retaining the two zones for the asymmetric treatment of emissions. The sign conventions are selected so that the normal values of the dual variables would be non-negative. The vector  $i$  is a column of ones so  $i^t E_{II}$  represents the sum of the exports.

$$\begin{array}{llll}
\text{Max} & B_I(d_I) + B_{II}(d_{II}) - C_I(g_I) - C_{II}(g_{II}) - C_E(E_{II}) - \delta i^t E_{II} & & \\
& \substack{d_I, d_{II}, g_I, g_{II}, E_{II} \geq 0; y_I, y_{II}} & & \\
& d_I - g_I = y_I & \text{Net Loads} & \rho_I \\
& d_{II} - g_{II} = y_{II} & & \rho_{II} \\
& i^t y_I + i^t y_{II} = 0 & \text{Load Balance} & \lambda \\
& H_I y_I + H_{II} y_{II} \leq b & \text{Transmission Limits} & \mu \\
& E_{II} \leq g_{II} & \text{Export Limits} & \theta \\
& -i^t y_{II} \leq i^t E_{II} & \text{Export Requirement} & \eta.
\end{array}$$

To analyze the price impacts set up the Lagrangian:

$$\begin{array}{l}
\text{Max} \\
\substack{d_I, d_{II}, g_I, g_{II}, E_{II} \geq 0; y_I, y_{II}} \\
L = B_I(d_I) + B_{II}(d_{II}) - C_I(g_I) - C_{II}(g_{II}) - C_E(E_{II}) - \delta i^t E_{II} \\
+ \rho_I(y_I - d_I + g_I) + \rho_{II}(y_{II} - d_{II} + g_{II}) - \lambda(i^t y_I + i^t y_{II}) \\
+ \mu^t(b - H_I y_I - H_{II} y_{II}) + \theta^t(g_{II} - E_{II}) + \eta(i^t E_{II} + i^t y_{II}).
\end{array}$$

Focus on an interior solution to simplify the description of the prices, which must satisfy:

$$d_I: \rho_I = \nabla B_I(d_I).$$

$$d_{II}: \rho_{II} = \nabla B_{II}(d_{II}).$$

$$y_I: \rho_I = \lambda i + H_I^t \mu.$$

$$y_{II}: \rho_{II} = \lambda i + H_{II}^t \mu - \eta.$$

$$g_I: \rho_I = \nabla C_I(g_I).$$

$$g_{II}: \rho_{II} = \nabla C_{II}(g_{II}) - \theta.$$

$$E_{II}: \theta = [\eta - \delta]i - \nabla C_E(E_{II}).$$

Or  $\rho_{II} = \nabla C_{II}(g_{II}) - [\eta - \delta]i + \nabla C_E(E_{II})$ . In other words,  $\rho_{II} + [\eta - \delta]i = \nabla C_{II}(g_{II}) + \nabla C_E(E_{II})$ .

The locational prices  $\rho_I, \rho_{II}$  reflect the asymmetry in the CARB implementation as proposed for the CAISO EIM. From the perspective of load and generation within Zone I, the LMP prices

satisfy the usual relationship, and equal both the marginal benefit of load and the marginal cost of generation at each location.

The situation is different in Zone II. Everything looks the same for load in Zone II, where the LMP equals the marginal benefit of meeting load. But for the generators in Zone II, the energy prices can differ from their marginal energy costs to incorporate the effect of the marginal cost of emissions exports. Hence, the energy price paid to generators is the marginal cost of generation ( $\nabla C_{II}(g_{II})$ ) plus the marginal cost of emissions ( $\nabla C_E(E_{II})$ ) less the net system marginal value of emissions as in  $(\eta - \delta)$ . In other words, the locational energy price plus the system marginal opportunity value of carbon associated with exports equals the marginal generation cost plus the marginal carbon costs for exports for each generator.

The protocol now recognizes that the energy prices will produce three types of constraint rents. The first is the usual congestion rent, which should flow to transmission owners and holders of Financial Transmission Rights (FTRs) as in the standard model. The second rent is an emission net value rent which will equal  $[\eta - \delta]i^t E_{II}$ . The proposal is that this revenue should be returned to the Zone II generators in proportion to their individual exports ( $[\eta - \delta]E_{II}$ ). The third rent is the balance from the penalty to mitigate import leakage, which will equal  $\delta i^t E_{II}$ . This import leakage charge would not be rebated through the dispatch settlements. The net effect is that the energy plus export reimbursement payments would guarantee that the net operating profits of the Zone II generator would be (abusing the notation to mean at each location in II):

$$\begin{aligned} \rho_{II} q_{II} + [\eta - \delta] E_{II} - C_{II}(g_{II}) - C_E(E_{II}) = \\ (\nabla C_{II}(g_{II}) - [\eta - \delta]i + \nabla C_E(E_{II})) q_{II} + [\eta - \delta] E_{II} - C_{II}(g_{II}) - C_E(E_{II}) \geq 0. \end{aligned}$$

The inequality guaranteeing non-negative operating profits assumes the cost functions are convex. And at the margin the Zone II generator is indifferent between both incremental generation and incremental export. Hence the prices support the solution.

This leaves the system with the net fee on imports that would not revert to the generators,  $\delta i^t E_{II}$ . As with a carbon tax, treatment of this component must be kept separate from the dispatch to support the efficient dispatch by maintaining consistency of prices and the incentive to follow the dispatch.



## References

- California Air Resources Board. (2017). California Cap n Greenhouse Gas Emissions and Market-Based Compliance Mechanisms. Retrieved from [https://www.arb.ca.gov/cc/capandtrade/capandtrade/unofficial\\_ct\\_030116.pdf](https://www.arb.ca.gov/cc/capandtrade/capandtrade/unofficial_ct_030116.pdf)
- California Independent System Operator. (2017a). Business Practive Manual: Energy Imbalance Market. Retrieved from <https://bpmcm.caiso.com/Pages/BPMDetails.aspx?BPM=Energy Imbalance Market>
- California Independent System Operator. (2017b). *EIM Greenhouse Gas Enhancement Revised Draft Final Proposal*. Retrieved from [http://www.google.se/url?sa=t&rct=j&q=&esrc=s&source=web&cd=1&cad=rja&uact=8&ved=0ahUKEwiTyeeLq\\_7UAhUEApoKHYWxAooQFggqMAA&url=http%3A%2F%2Fwww.caiso.com%2FDocuments%2FRevisedDraftFinalProposal-EnergyImbalanceMarketGreenhouseGasEnhancements.pdf&usg=AFQjCNE](http://www.google.se/url?sa=t&rct=j&q=&esrc=s&source=web&cd=1&cad=rja&uact=8&ved=0ahUKEwiTyeeLq_7UAhUEApoKHYWxAooQFggqMAA&url=http%3A%2F%2Fwww.caiso.com%2FDocuments%2FRevisedDraftFinalProposal-EnergyImbalanceMarketGreenhouseGasEnhancements.pdf&usg=AFQjCNE)
- Gribik, P. R., Hogan, W. W., & Pope, S. L. (2007). Market-Clearing Electricity Prices and Energy Uplift. Retrieved from [http://www.hks.harvard.edu/fs/whogan/Gribik\\_Hogan\\_Pope\\_Price\\_Uplift\\_123107.pdf](http://www.hks.harvard.edu/fs/whogan/Gribik_Hogan_Pope_Price_Uplift_123107.pdf)
- Hogan, W. W. (2002). Electricity market restructuring: reforms of reforms. *Journal of Regulatory Economics*, 21(1), 103–132. Retrieved from <http://ezp-prod1.hul.harvard.edu/login?url=http://search.ebscohost.com/login.aspx?direct=true&db=bth&AN=17768581&site=ehost-live&scope=site>
- Hogan, W. W. (2013). *CAISO Energy Imbalance Market Straw Proposal: Comments*. Retrieved from [http://www.hks.harvard.edu/fs/whogan/Hogan\\_CAISO\\_EIM\\_Notes\\_062613.pdf](http://www.hks.harvard.edu/fs/whogan/Hogan_CAISO_EIM_Notes_062613.pdf)
- Hogan, W. W. (2014). *California Energy Imbalance Market Design*. Retrieved from [http://www.hks.harvard.edu/fs/whogan/Hogan\\_EIM\\_Comments\\_032814.pdf](http://www.hks.harvard.edu/fs/whogan/Hogan_EIM_Comments_032814.pdf)
- Hogan, W. W., & Pope, S. L. (2017). *Priorities for the Evolution of an Energy-Only Electricity Market Design in ERCOT*. Retrieved from [https://www.hks.harvard.edu/fs/whogan/Hogan\\_Pope\\_ERCOT\\_050917.pdf](https://www.hks.harvard.edu/fs/whogan/Hogan_Pope_ERCOT_050917.pdf)
- Newell, S. A., Lueken, R., Weiss, J., Spees, K., Donohoo-Vallett, P., & Lee, T. (2017). Pricing Carbon into NYISO's Wholesale Energy Market to Support New York's Decarbonization Goals. Brattle Group. Retrieved from [http://www.nyiso.com/public/webdocs/markets\\_operations/documents/Studies\\_and\\_Reports/Studies/Market\\_Studies/Pricing\\_Carbon\\_into\\_NYISOs\\_Wholesale\\_Energy\\_Market.pdf](http://www.nyiso.com/public/webdocs/markets_operations/documents/Studies_and_Reports/Studies/Market_Studies/Pricing_Carbon_into_NYISOs_Wholesale_Energy_Market.pdf)
- PJM. (2017). Advancing Zero Emissions Objectives through PJM ' s Energy Markets: A Review of Carbon-Pricing Frameworks. Retrieved from <http://www.pjm.com/~media/library/reports-notice/special-reports/20170502-advancing-zero-emission-objectives-through-pjms-energy-markets.ashx>
- Rudkevich, A. M., & Ruiz, P. A. (2012). Locational Carbon Footprint of the Power Industry: Implications for Operations, Planning and Policy Making. In Q. P. Zheng, S. Rebennack, P. M. Pardalos, M. V. F. Pereira, & N. A. Iliadis (Eds.), *Handbook of CO<sub>2</sub> in Power Systems*

---

<sup>i</sup> William W. Hogan is the Raymond Plank Professor of Global Energy Policy, John F. Kennedy School of Government, Harvard University. This paper draws on research for the Harvard Electricity Policy Group and for the Harvard-Japan Project on Energy and the Environment. The author is or has been a consultant on electric market reform and transmission issues for Allegheny Electric Global Market, American Electric Power, American National Power, Aquila, Atlantic Wind Connection, Australian Gas Light Company, Avista Corporation, Avista Utilities, Avista Energy, Barclays Bank PLC, Brazil Power Exchange Administrator (ASMAE), British National Grid Company, California Independent Energy Producers Association, California Independent System Operator, California Suppliers Group, Calpine Corporation, CAM Energy, Canadian Imperial Bank of Commerce, Centerpoint Energy, Central Maine Power Company, Chubu Electric Power Company, Citigroup, City Power Marketing LLC, Cobalt Capital Management LLC, Comision Reguladora De Energia (CRE, Mexico), Commonwealth Edison Company, COMPETE Coalition, Conectiv, Constellation Energy, Constellation Energy Commodities Group, Constellation Power Source, Coral Power, Credit First Suisse Boston, DC Energy, Detroit Edison Company, Deutsche Bank, Deutsche Bank Energy Trading LLC, Duquesne Light Company, Dyon LLC, Dynegy, Edison Electric Institute, Edison Mission Energy, Electricity Corporation of New Zealand, Electric Power Supply Association, El Paso Electric, Energy Endeavors LP, Exelon, Financial Marketers Coalition, FirstEnergy Corporation, FTI Consulting, GenOn Energy, GPU Inc. (and the Supporting Companies of PJM), GPU PowerNet Pty Ltd., GDF SUEZ Energy Resources NA, Great Bay Energy LLC, GWF Energy, Independent Energy Producers Assn, ISO New England, Koch Energy Trading, Inc., JP Morgan, LECG LLC, Luz del Sur, Maine Public Advocate, Maine Public Utilities Commission, Merrill Lynch, Midwest ISO, Mirant Corporation, MIT Grid Study, Monterey Enterprises LLC, MPS Merchant Services, Inc. (f/k/a Aquila Power Corporation), JP Morgan Ventures Energy Corp., Morgan Stanley Capital Group, Morrison & Foerster LLP, National Independent Energy Producers, New England Power Company, New York Independent System Operator, New York Power Pool, New York Utilities Collaborative, Niagara Mohawk Corporation, NRG Energy, Inc., Ontario Attorney General, Ontario IMO, Ontario Ministries of Energy and Infrastructure, Pepco, Pinpoint Power, PJM Office of Interconnection, PJM Power Provider (P3) Group, Powerex Corp., Powhatan Energy Fund LLC, PPL Corporation, PPL Montana LLC, PPL EnergyPlus LLC, Public Service Company of Colorado, Public Service Electric & Gas Company, Public Service New Mexico, PSEG Companies, Red Wolf Energy Trading, Reliant Energy, Rhode Island Public Utilities Commission, Round Rock Energy LP, San Diego Gas & Electric Company, Secretaría de Energía (SENER, Mexico), Sempra Energy, SESCO LLC, Shell Energy North America (U.S.) L.P., SPP, Texas Genco, Texas Utilities Co, Tokyo Electric Power Company, Toronto Dominion Bank, Transalta, TransAlta Energy Marketing (California), TransAlta Energy Marketing (U.S.) Inc., Transcanada, TransCanada Energy LTD., TransEnergie, Transpower of New Zealand, Tucson Electric Power, Twin Cities Power LLC, Vitol Inc., Westbrook Power, Western Power Trading Forum, Williams Energy Group, Wisconsin Electric Power Company, and XO Energy. The author has benefitted from discussions with anonymous reviewers. The views presented here are not necessarily attributable to any of those mentioned, and any remaining errors are solely the responsibility of the author. (Related papers can be found on the web at [www.whogan.com](http://www.whogan.com)).